

OWNER'S MANUAL

For Models: A10-205 ■ A10-215

Stainless Steel Gas Grill



U.S. PATENTS
4,788,962
5,330,154
5,413,090
D 292,163
Other Patents and Design
Patents Pending

Made in the
USA 



For questions regarding performance, assembly, operation, parts, or returns, contact the experts at MAGMA by calling **(562) 627-0500** 7:00 a.m. - 5:00 p.m. Pacific Time Monday thru Friday or e-mail us at mail@MagmaProducts.com

MAGMA[®]

U S A

IMPORTANT, read these instructions carefully before use. Familiarize yourself with the appliance before connecting it to its gas container. Keep these instructions for future reference.

IMPORTANT SAFETY WARNINGS

READ ALL INSTRUCTIONS BEFORE OPERATING.

- USE OUTDOORS ONLY.
- DO NOT USE THIS APPLIANCE INSIDE THE BOAT OR ANY ENCLOSED SPACE.
- GRILLS RADIATE HEAT. CLEARANCE FROM COMBUSTIBLES, 24" SIDES AND BACK. NEVER USE UNDER AWNINGS, PATIO COVERS, ETC.
- USE PROPANE GAS ONLY. FUEL STORAGE SHOULD BE IN COMPLIANCE WITH THE AMERICAN BOAT AND YACHT COUNCIL (ABYC) STANDARDS A-1 (9), MARINE LIQUIFIED PETROLEUM GAS (LPG) SYSTEMS.
- FOR NATURAL GAS APPLICATION CONTACT MAGMA.
- ALWAYS LIGHT GRILL WITH LID OPEN.
- NEVER LEAVE HOT GRILL UNATTENDED.
- DO NOT OVERHEAT GRILL, SEE OPERATING INSTRUCTIONS
- ALWAYS TURN GRILL OFF AFTER USE.
- USE GLOVE OR HOT PAD WHEN HANDLING HOT GRILL.
- NEVER LEAVE GAS CYLINDERS AND REGULATOR CONNECTED WHEN STOWED.
- STORE GAS CYLINDERS IN WELL VENTILATED AREA.
- DO NOT STORE GAS CYLINDERS INDOORS, IN DIRECT SUNLIGHT, BELOW DECKS ON BOATS, OR IN LOCKERS NOT APPROVED FOR BUTANE OR PROPANE STORAGE.
- CAUTION: CHECK FOR GAS LEAKS EACH TIME CYLINDER IS CHANGED.
- NEVER CHECK FOR GAS LEAKS WITH A FLAME!
- DO NOT BLOCK, RESTRICT, OR OTHERWISE OBSTRUCT COMBUSTION OR VENTILATION AIR OPENINGS.
- DO NOT MODIFY THIS APPLIANCE.
- CHECK THAT VALVE SEALING WASHER (A) IS IN PLACE AND IN GOOD CONDITION BEFORE CONNECTING THE GAS CONTAINER.
- INSTALL CANISTERS IN WELL VENTILATED AREA AND AWAY FROM OPEN FLAME, HEAT SOURCE OR SPARKS. KEEP AWAY FROM OTHER PEOPLE OR FLAMMABLE MATERIALS.



CONTENTS

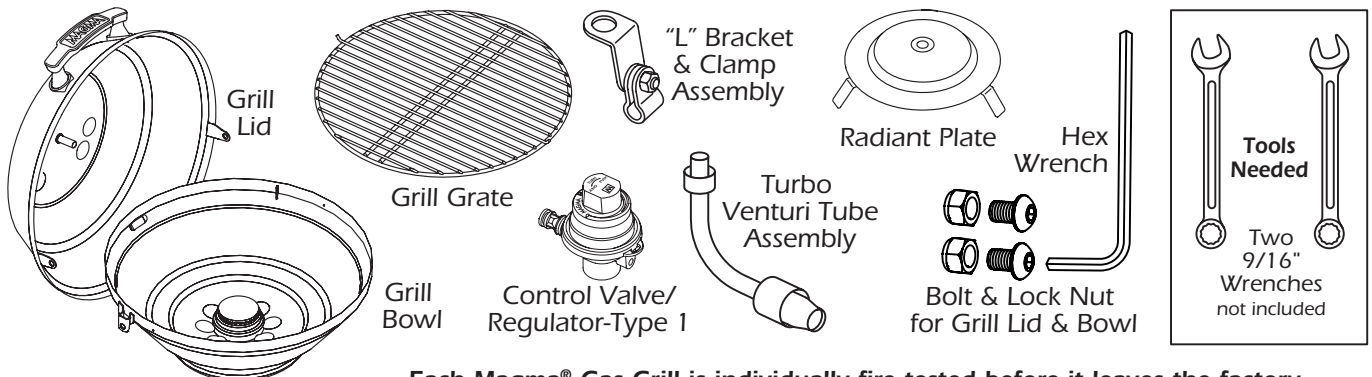

Each Magma® Gas Grill is individually fire tested before it leaves the factory. For this reason, the burner on your grill may be slightly discolored.

ATTACH THE LID TO THE BOWL

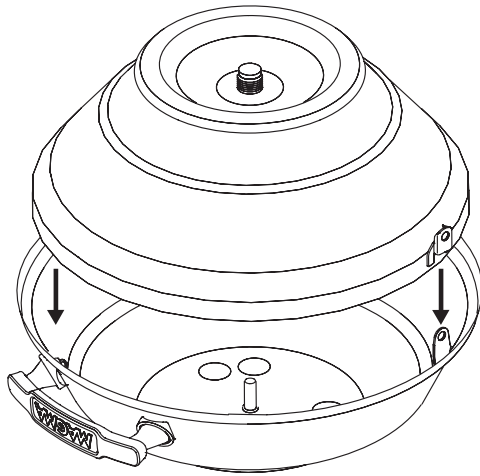

A

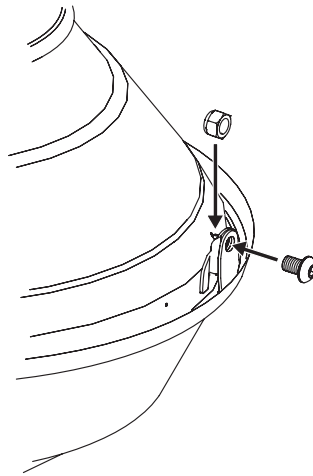

B

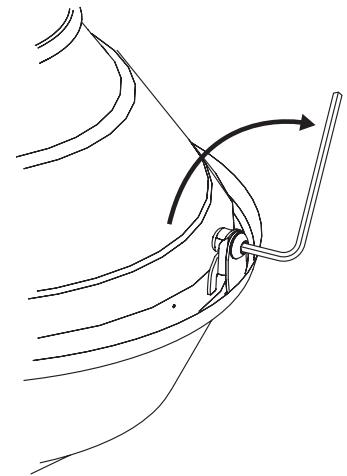

C

SETTING UP YOUR GRILL

Mounts sold separately. See our website www.MagmaProducts.com for mounting options.



- 1** Select and install appropriate Magma mount in your desired location. Prior to installing the grill, check that mount does not easily move with a reasonable force applied.
- 2** Next, decide if gas control valve will be easier to access from the center right side or center left side of grill. This will be based on your placement of the mount (**see picture front cover**). Now, slide L-Bracket & Clamp on to mount knurled rod so that the threaded flat L-portion of the L-Bracket points in that direction (see above).
- 3** Adjust threaded flat surface of L-Bracket to level position and tighten firmly with two 9/16" or adjustable wrenches so that L-Bracket & Clamp cannot be moved. NOTE: Level positioning is critical for even temperatures across the cooking surface.
- 4** Carefully hold the grill body, with the lid closed, and thread on to L-Bracket **VERY TIGHT** so that grill does not unthread easily. Check that grill is tight and level prior to proceeding.

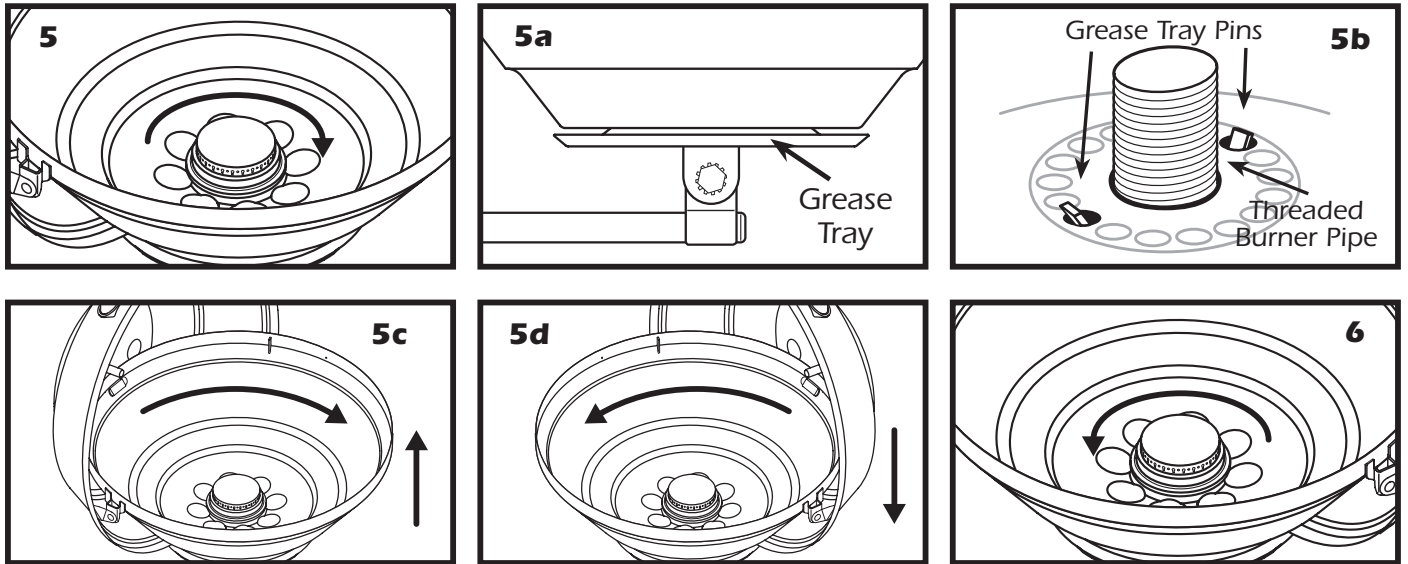

5 With grill body tightly attached to L-Bracket, unthread burner **3 full revolutions only**. **CAUTION: DO NOT UNTHREAD MORE THAN 3 REVOLUTIONS, AS GRILL MAY FALL OVERBOARD.**

- Lift entire grill up to disengage from grease tray positioning pins (**5a & 5b**) and rotate so lid operates freely in desired position (**5a**).
- Carefully lower back down (**5d**), making sure pins are re-engaged and rethreaded "burner" back 3 revolutions until tight (**6**). If burner does not turn 3 revolutions the pins are not engaged properly.

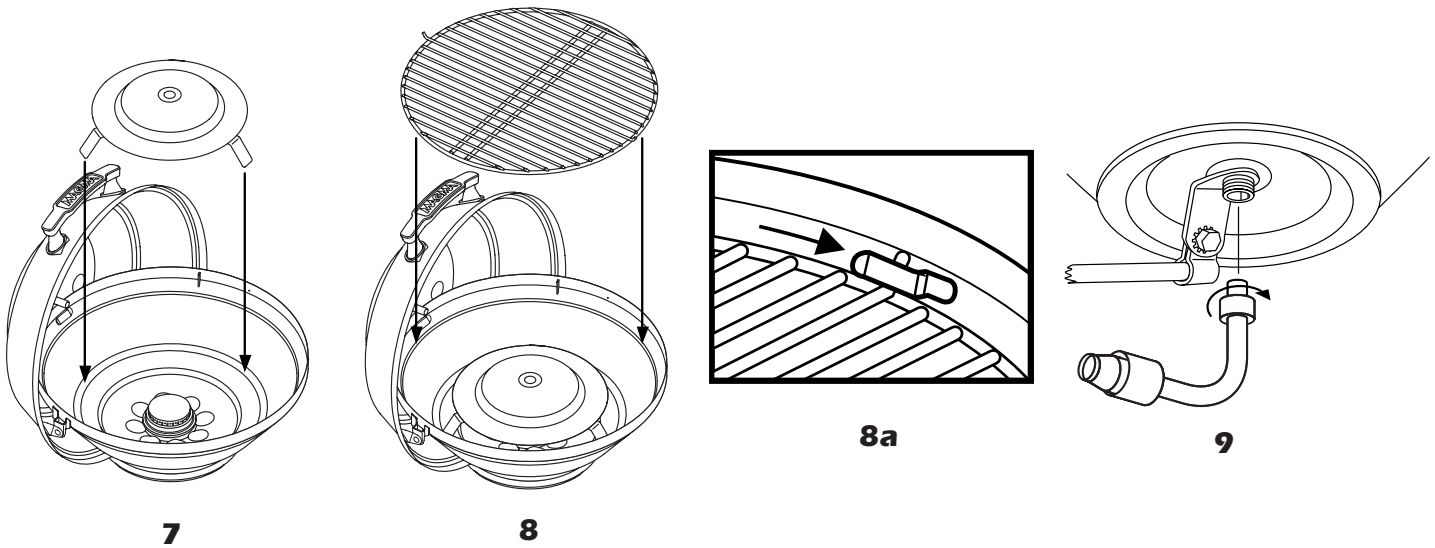

- 7** Install radiant plate over burner on bowl ridge.
- 8** Install grill grate by rotating grate so that both grill grate tabs slide under the holding clips (**8a**), locking grate and all internal components in correct position.
- 9** Insert the venturi tube into the threaded pipe on the bottom of the grill body and firmly tighten the threaded nut so nut doesn't turn while rotating the turbo venturi tube. Note: venturi tube should still rotate freely. Venturi tube should be stowed with valve in a clean dry environment when not in use. (See "Stowing Tips" page 6) Before each use, prior to inserting venturi tube, check that the threaded pipe is free of spider web obstructions.

CONNECTING FUEL SOURCE

CONTROL VALVE REGULATOR

- Uses standard 1-lb. disposable propane canisters (DOT-39 NRC).
- Prior to installing valve, become familiar with the valve function and graphics on valve knob. Never force the knob. Always turn or push gently.
- Turn control valve to "lock" and install gas canister being careful not to cross the threads. Check for leaks prior to use, by brushing soapy water solution around threads and orifice hole checking for bubbles.

Valve will feel loose and will rotate easily. Even though the valve feels loose, it is designed that way and will not leak. The valve was designed to be loose fitting in order to allow safe, easy installation and removal of the propane canister and so it easily swings without resistance to fit all applications.

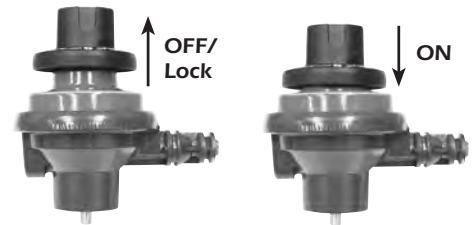
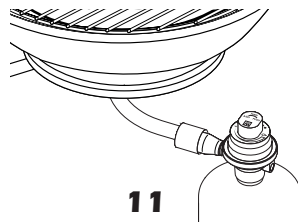
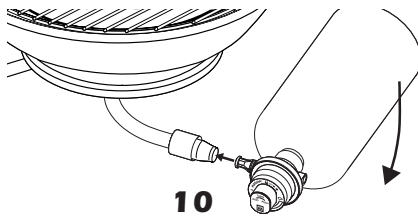
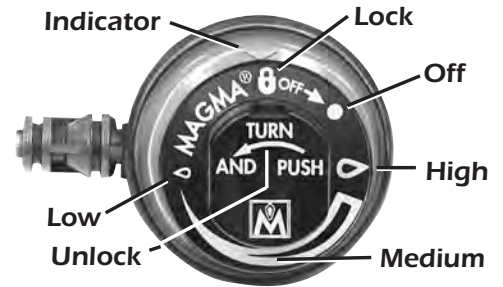

USING GRILL WITH ON-BOARD LPG (PROPANE) SYSTEMS

- Magma On-Board LPG (Propane) Valves and Lpg (Propane) Low Pressure Gas Grill Connection Kits allow Magma Grills to be installed within a boats existing on-board, pre-regulated low pressure LPG (Propane) system.

- Use only **Magma Type 3 Low Pressure LPG (Propane) Valves**. See our **Valve Application Guide** at www.MagmaProducts.com for correct valve.



- In North America use **Magma A10-225 LPG 10' Gas Grill Connection Kit** in conjunction with **Type 3 Valve**. Outside North America check your local dealer for proper hose and fittings.
- A primary shutoff valve (**supplied with Gas Grill Connection Kit**) must be used with this control valve at point of connection into your system. This allows shut off of gas supply to hose leading to grill.

Gently insert valve stem into venturi tube upside down until fully inserted and rotate as shown.

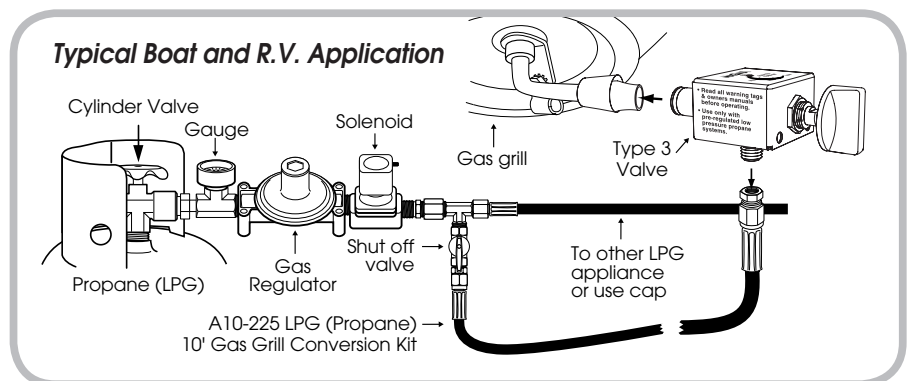

IMPORTANT!! ▪ DO NOT CONNECT A HIGH-PRESSURE SUPPLY HOSE FROM A NON-REGULATED TANK DIRECTLY TO GRILL.

Magma's grills are designed for use with small disposable propane canisters or with pre-regulated low-pressure propane and optional low-pressure valves. Running high-pressure propane fuel supply lines on a boat is in violation of American Boat & Yacht Council (ABYC) guidelines and is not considered a safe application. Additionally, impurities found in larger refillable propane tanks may clog the small orifices in the high-pressure control valve/ regulator causing it to lose performance capabilities and eventually fail. Regulating these tanks to 1/2 PSI and using this pre-regulated propane with the correct low-pressure valve will insure safe, efficient performance of the grill.

OPERATING PROCEDURES

WARNING: Do not overheat grill. Magma grills do not require pre-heating. Stainless Steel loses anti-corrosive characteristics when subjected to extreme heat. Most grilling is done on low temperature with the lid closed. If medium or high heat is required, grill with lid open.

LIGHTING INSTRUCTIONS

- Open lid during lighting. ▪ When igniting grill, use a long nozzle butane lighter.
- To ignite grill, first ignite lighter or match flame, put flame to outer edge of Radiant Plate, then turn valve to high "large ". ▪ To grill, cook with lid on.

To help create your own Magma gourmet experience every time you grill, please check these important critical points prior to lighting your grill.

- Mount is secure and grill does not move. ▪ Grease tray and fire pan are clean from excess drippings to reduce flare up and ensure even air flow. ▪ Lid is correctly positioned to operate freely and is in best position for blocking the wind.
- Venturi tube, burner, threaded burner pipe and valve orifice are free of obstructions, such as spider webs. ▪ Radiant plate is positioned correctly. ▪ Grill grate is in locked position under holding clips. ▪ Turbo Venturi Tube holding nut is tight & doesn't turn when rotating valve position. ▪ Valve is installed and locked into Turbo Venturi Tube properly. ▪ Sufficient fuel is available.

Cooking Tips

- The most common mistake when grilling is using too high of a heat setting. Grills become hotter as you cook, so use moderate heat settings when cooking with lid closed. ▪ Always keep a water spray bottle handy for flare ups and quick cooling if grill overheats. ▪ Coat the grill grate with vegetable or olive oil to prevent food from sticking.

Stowing Tips

- Always disconnect the fuel canister from the valve prior to stowing.
- Stow the valve and Turbo Venturi Tube in a clean, dry area to protect from corrosion to valve and spider web obstructions in venturi tube.
- Always stow by unthreading the entire grill from the L-Bracket. Do not remove the L-Bracket & Clamp unless repositioning is necessary.
- Always store propane in a sealed propane storage locker that allows leakage to vent overboard or use **Magma A10-210 Propane Storage Tote**. Never stow below decks.

MAINTENANCE

Complete Disassembly for Cleaning

- 1 - Remove entire grill body from L-Bracket of Mount.
- 2 - Unthread and remove burner, Flame Deflector and grease tray from bowl.
- 3 - To reassemble, reverse above steps and steps 6 through 9 from page 4 "Setting Up Your Grill".

Stainless steel contrary to popular belief can rust. Most commonly, deposits on surface of the product will trap moisture. It is this moisture that robs stainless steel of oxygen. Oxygen is the element that reacts with stainless steel to form a protective layer of chrome oxide. Robbed of oxygen, this reaction does not take place and "crevice corrosion" or "surface rusting" occurs. To minimize this effect, thoroughly clean your grill with soap and water, rinse with fresh water, and dry. Avoid using stainless steel polishes on grill exterior as most leave a residue that may discolor when grill is heated.

Additionally, stainless steel that is exposed to high heat will change color and texture over time. The "amber" color of grill exterior and internal components is not a failure of the stainless steel and will not affect products operation. When this happens, we recommend using "**Magma Magic**" **Grill Restorer** to remove the "amber" color and return grill to its original luster. However, prolonged exposure to extreme high heat will cause chromium and nickel to "burn out" of stainless steel. At this point stainless steel will become more susceptible to corrosion and will start to deteriorate. We recommended replacement of internal components as they become seriously deteriorated.

We recommend thoroughly cleaning grill and internal components after each outing. Disassemble interior components and remove all food residue. Use a "Scotch Brite" pad or similar product and "Easy-Off" oven cleaner for cleaning grills interior components, followed by thoroughly washing with soap and water, rinse with fresh water & dry. AVOID CONTACT OF OVEN CLEANER WITH SKIN, CONTROL VALVE, AND BOAT SURFACE. CAUTION: DO NOT USE ANY TYPE OF ABRASIVE PAD ON EXTERIOR MIRROR FINISH AS IT WILL SCRATCH SURFACE, USE ONLY A SOFT CLOTH. We recommend covering grill between uses. Grill covers are available at Magma retailers or directly from Magma. See our website, www.magmaproducts.com

Grill Grates

Clean with brass wire brush while grill is warm. Use Oven & Grill cleaner for burnt-on residue. Wash with soapy water and dry prior to storage.

Control Valve

All valves are set and tested at our factory. Do not attempt to adjust or disassemble the valve. Call Magma if you suspect it is not adjusted properly. Clean valve with a cloth and remove any debris obstructing the orifice.

Repair/Replacement Parts

All replacement parts are readily available at your Magma Retailers or directly from Magma. For a complete list of replacement parts, see page 8, or visit our website www.MagmaProducts.com.

REPLACEMENT PARTS

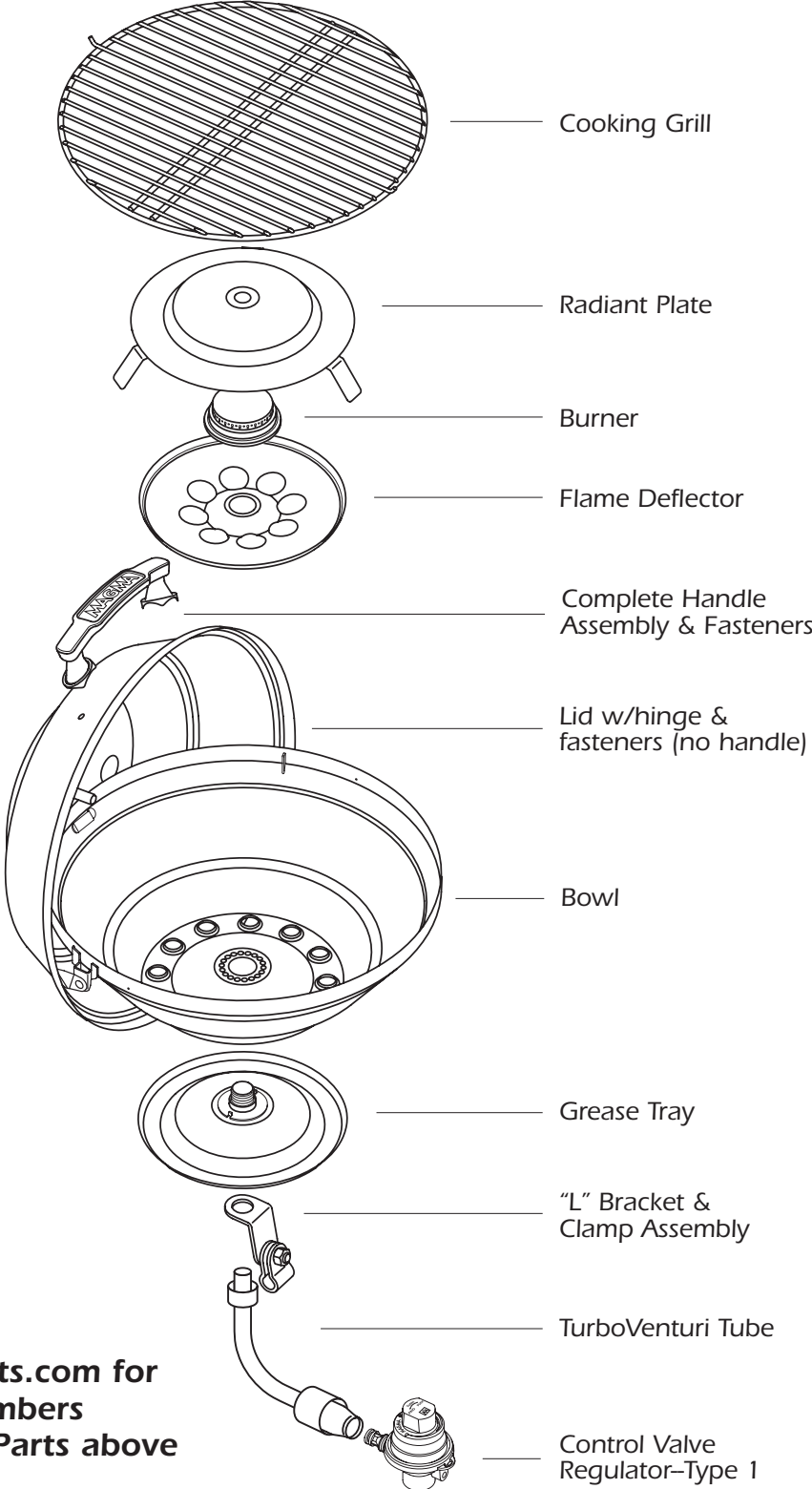

Please see www.MagmaProducts.com for correct part numbers for the Replacement Parts above

TROUBLE SHOOTING GUIDE

Problem	Possible Cause	Possible Solution
Burner will not light	<p>No gas flow</p> <p>Obstructed gas flow</p>	<p>Check fuel level, replace canister or refill cylinder</p> <p>Clean burner, turbo venturi tube, and valve orifice. Remove debris/spider webs</p>
Flare-up	<p>Excessive cooking temperature</p> <p>Grease and/or residue build-up</p> <p>Excessive fat in meats</p> <p>Excessive oils in marinades</p>	<p>Operate only on low when lid is closed Reduce flame level Leave lid open Use water spray to cool</p> <p>Clean components</p> <p>Trim fat from cuts of meat before grilling</p> <p>Use non-oil based marinades</p>
Yellow sooty flame	<p>Obstructed gas flow</p>	<p>Clean burner, turbo venturi tube, and valve orifice. Remove debris/spider webs</p>
Blow-out	<p>Flame too low</p> <p>Wind directly on burner</p> <p>Obstructed gas flow</p>	<p>Increase flame</p> <p>Block wind with lid. See page 4</p> <p>Clean burner, turbo venturi tube, and valve orifice. Remove debris/spider webs</p>
Hot Spots	<p>Grill not level</p> <p>Grease or residue build-up</p> <p>Excessive fat in meats</p> <p>Excessive oil in marinades</p>	<p>Level Grill. See page 3</p> <p>Clean components</p> <p>Trim fat from cuts of meat before grilling</p> <p>Use non-oil based marinades</p>

ACCESSORIES



Magma® Marine Kettle® Grill Cover/Tote Bag
Original & Party Size

sunbrella™



"Telescoping" Grill Tools and Storage/Carrying Case



LPG (Propane) Low Pressure Gas Grill Connection Kit
for on-board LPG (Propane) systems ▪ North America Only



Stores in less than 1/2 cubic foot



LED Grill Light
High-intensity LED light for grilling after dark



Low Pressure Control Valves for on-board LPG (Propane) or CNG (Natural Gas) gas systems



Fully "Nesting" Cookware 7 or 10 Piece Sets. 18-10 Stainless Steel or 18-10 Stainless Steel with Cobalt Blue Enamel Exterior. All Sets Also Available With Ceramica® Non-Stick Cooking Surfaces and Induction.



Stores in less than 1/2 cubic foot



Fish & Veggie Grill Tray
18-9 Stainless Steel or 18-9 Stainless Steel with Non-Stick



Reversible "Non-Stick" Griddle
Heavy duty marine grade cast aluminum with Non-Stick Coating



Propane/Butane Canister Storage Locker/Tote Bag



Magma Magic Grill Restorer Removes amber color from all Magma Grills - USA only



"Marine Cuisine"® Grill Guide & Cookbook

See our website www.MagmaProducts.com for a complete list of accessories

LIMITED WARRANTY

Magma Products, Inc. guarantees this product to be free from defects in materials or workmanship to the original consumer. This guarantee is for the periods herein specified when used under normal and reasonable conditions, one (1) year from the date of original purchase. This warranty does not include the cost of property damage or any inconvenience due to the failure of the product. Nor does it cover damage due to misuse, abuse, accident, or damage resulting from transportation of the product. Nor does it include damage resulting from the commercial use of this product. Nor does it include, on stainless steel products, "Surface Rust"; Excessive Corrosion due to exposure to salt water; or Discoloration or Corrosion caused by exposure to excessive heat or failure to properly clean and care for the stainless steel surfaces. If the product fails to operate due to a defect in materials or workmanship during the warranty period, the defective part will be repaired or replaced at Magma's option. If you wish to obtain performance under this limited warranty, you should contact Magma's Customer Service Department via telephone at (562) 627-0500, or via e-mail at mail@MagmaProducts.com, or via U.S. Postal Service mail at "Magma Products, Inc., Attention Customer Service, 3940 Pixie Ave, Lakewood, CA, 90712". The defective part, along with proof of purchase, must be returned postage prepaid to Magma Products, Inc. We suggest that you keep your purchase receipt as we may require reasonable proof of purchase.

In the state of California only, if refinishing or replacement of the product is not commercially practicable, the retailer selling the product, or Magma Products, Inc., will refund the purchase price paid for the product, less the amount directly attributable to use by the original consumer prior to the discovery of the nonconformity. In addition, in the state of California only, you may take the product to the retail establishment from which it was purchased or to any retail establishment selling this product in order to obtain performance under this warranty. All implied warranties, including the implied warranties of merchantability and fitness for a particular purpose, are limited in duration to the express warranty periods specified herein for the parts described herein. Some states do not allow limitations on how long an implied warranty lasts, so the above limitation may not apply to you. Neither Magma dealers, nor the retail establishment selling this product has any authority to make any warranties or to promise remedies in addition to or inconsistent with those stated above. Magma's maximum liability shall not exceed the purchase price of the product paid by the original consumer. Some states do not allow the exclusion or limitation of incidental or consequential damages, so the above limitation or exclusions may not apply to you. The warranty gives you specific legal rights and you may also have other rights which vary from state to state.

MAGMA and the Magma logo are registered trademarks of Magma Products, Inc. ▪ Patent pending.

CALIFORNIA PROPOSITION 65 – WARNING – The burning of gas cooking fuel generates some by-products, which are on the list of substances, which are known by the State of California to cause cancer or reproductive harm. California law requires businesses to warn customers of potential exposure to such substances. To minimize exposure to these substances, always operate this unit according to the use and care manual, ensuring you provide good ventilation when cooking with gas.

MAGMA®

U S A

Magma Products, Inc. 3940 Pixie Avenue, Lakewood, CA 90712 ▪ USA ▪ Phone (562) 627-0500
e-mail: mail@MagmaProducts.com ▪ www.MagmaProducts.com

• ADDENDUM FOR GAS GRILL MODELS A10-205CE-2 / A10-215CE-2

- L'ADDENDUM POUR LE GRIL DE GAZ MODELE A10-205CE-2 / A10-215CE-2
- NACHTRAG FÜR GAS GRILL ENTWIRFT A10-205CE-2 / A10-215CE-2
- L'ADDENDUM PER LA GRIGLIA DI GAS MODELLO A10-205CE-2 / A10-215CE-2
- EI APENDICE PARA LA PARRILLA DE GAS MODELO A10-205CE-2 / A10-215CE-2
- ADDENDUM VOOR GASGRILL MODELLEERT A10-205CE-2 / A10-215CE-2

• Use "Camping Gaz"® Propane/Butane mix fuel only, in disposable canisters (CV-270 or CV-470).

- Utiliser « Campant Gaz » ® le carburant de mélange de Propane/Butane seulement, dans les boîtes métalliques à jeter (CV- 270 ou CV-470).
- Benutzen Sie „Lagern Gaz“ ® Propan/Butanmischungskraftstoff nur, in verfügbaren Dosen (CV- 270 oder CV-470).
- Usare "di Campeggiare Gaz" ® il carburante di miscela di Propano/Butano soltanto, nelle scatole di metallo disponibili (CV-270 o CV-470).
- Utilice "Acampando Gaz" ® el combustible de la combinación de Propano/Butano sólo, en botes para tirar (CV-270 o CV-470).
- Gebruik "Kamperen Gaz" ® de Propaan/Butaan mengsel brandstof enkel, in beschikbare granaten (CV- 270 of CV-470).

