

WH95FC

14" Marine Crescent Ice Maker • Marine Series



FEATURES & BENEFITS



WHITE SOLID
(FLANGE TO
CABINET)

PERFORMANCE	<ul style="list-style-type: none"> • Uses less than 3 gallons (11,4 litres) of water to produce up to 23 lb (10,4 kg) of ice per day • Up to 12 lb (5,4 kg) in ice storage capacity • Crescent ice cube dimensions: 1/2" W x 3/4" H x 2 1/4" L (12,7 mm W x 19 mm H x 57 mm L) • On/Off switch is conveniently located on the grille • Available in 115 or 220-240 volts
INTERIOR/EXTERIOR	<ul style="list-style-type: none"> • No drain required • Door swing is field reversible, and is shipped right-hand hinged • Standard travel package includes door latch, ensuring safe-at-sea storage • Corrosion and UV resistant components provide product longevity in harsh environments
INTEGRATION	<ul style="list-style-type: none"> • Unit is designed to be built-in or can be freestanding • 1/2" (12,7 mm) flange mounts flush to cabinet

MODEL DETAILS

Model	Voltage/Hz	Door Swing	Finish	Shipping Weight
ULN-WH95FC-03A	115 / 60	Field Reversible (Flange to Cabinet)	White Solid	62 lb (28 kg)
ULN-WH95FC-20A	220-240 / 50	Field Reversible	White Solid	62 lb (28 kg)

ACCESSORIES

Model	Description	Finish	Shipping Weight
ULAWATERHOOKUP	Braided water supply line kit	N/A	2 lb
U-POWERCORD-2056	Power Cord 220 - 240 V Great Britain/Ireland	N/A	N/A
U-POWERCORD-2256	Power Cord 220 - 240 V Australia/New Zealand	N/A	N/A
U-POWERCORD-2667	Power Cord 220 - 240 V Continental Europe	N/A	N/A
U-POWERCORD-3071	Power Cord 220 - 240 V China	N/A	N/A
U-POWERCORD-3111	Power Cord 220 - 240 V India	N/A	N/A

*Power cord type must be specified with each U-Line order; no additional cost for power cord.

DIMENSIONS

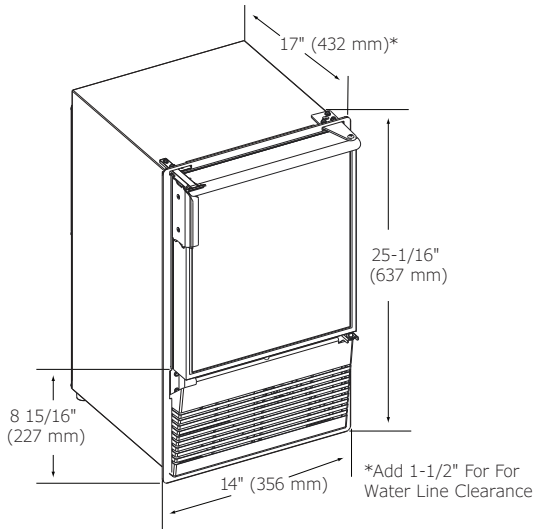

SPECIFICATIONS

Model	WH95FC
Amps: Running (115v)	1.2 amps
Amps: Running (220-240v)	1.2 amps
Amps: Max Start Up (115v)	18 amps
Amps: Max Start Up (220-240v)	6 amps
Control Type	On/Off Switch
Defrost Type	Manual
Dimensions: Product Depth	17" (432 mm)
Dimensions: Product Height	25 1/16" (637 mm)
Dimensions: Product Width	14" (356 mm)
ENERGY STAR	N/A
Ice Production Per Day	23 lb (10,4 kg)
Ice Storage	12 lb (5,4 kg)
Product Weight: Max	56 lb (25 kg)
Refrigerant Type	R134A
Sabbath (Star K Certified)	No

CABINET CUT-OUT

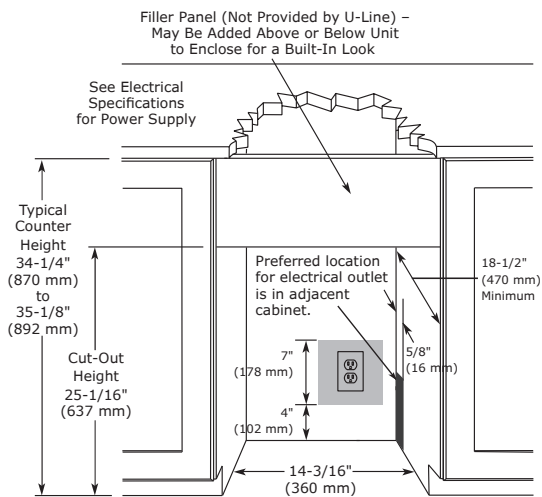

INSTALLATION NOTES

No additional clearance around sides, top or rear of unit is needed for ventilation.

Do not obstruct front grille air flow.



UL listing only applies to 115 v models.

CE only applies to 220-240v models.



Please visit u-line.com to view this model's User Guide & Service Manual. All Specifications are subject to change without notice.