

29<sup>th</sup> February 2016

Dear Valued Customer,

We are delighted to announce key enhancements to our Supersub Smart product range.

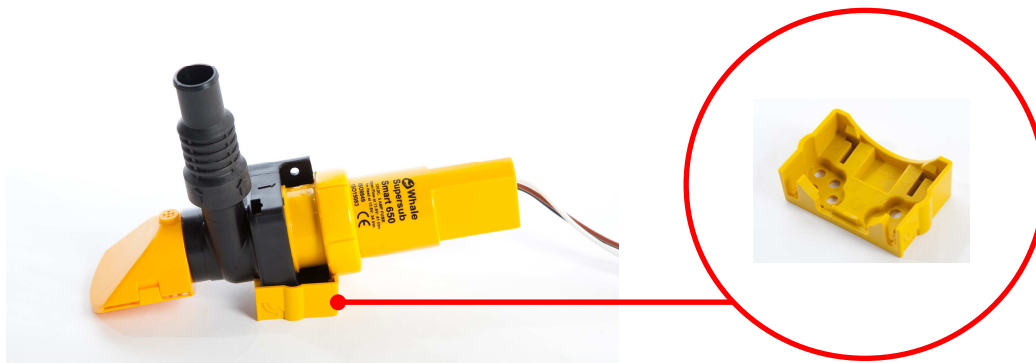

### 3 Year Warranty

Based on over 20 years designing and refining our low profile pump range and extensive lab and field testing, we are pleased to announce several new features to further enhance our sales messages for these pumps.

- **All Supersub Smart models (bulk and retail versions) are now covered by a Whale 3 year warranty . This 3 year warranty applies to production parts from January 2016 onwards indicated by Quality Assurance reference numbers starting with A16.\***
- **The Supersub Smart retail range now comes with a unique pre-assembled mounting bracket. This ensures that the pump sits at the ideal 8 degree angle for ease of installation and optimal performance. For an overview of how to fit the bracket see attached Installation Information.**

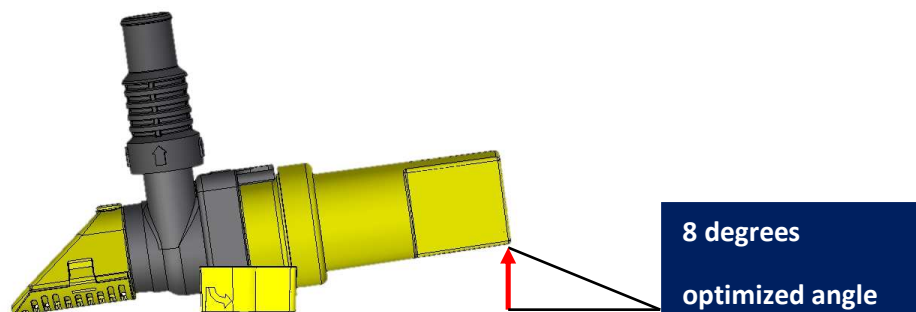

- **The Supersub Smart on/off timings have been optimized to prevent activation by wave motion or cycling, resulting in better drainage and improved reliability.**

These changes are effective immediately. Please see overleaf a list of the products affected:-



**Whale**

2 Enterprise Road, Bangor, Co. Down, N. Ireland  
Tel: +44 (0)28 9127 0531 info@whalepumps.com  
www.whalepumps.com

Whale Part Code	Description
Models now supplied with pre-installed wedge, optimized timings included and extended 3 year warranty	
SS5212	Supersub Smart - Low Profile Automatic Bilge Pump 650 US GPH , 12 V d.c.
SS1212	Supersub Smart - Low Profile Automatic Bilge Pump 1100 US GPH, 12 V d.c.
SS1224	Supersub Smart- Low Profile Automatic Bilge Pump 1100 US GPH- 24 V d.c.
Models now supplied with optimized timings and extended 3 year warranty	
SS1212B	Supersub Smart - Low Profile Automatic Bilge Pump 1100 US GPH, 12V Bulk Packaged
SS5212B	Supersub Smart - Low Profile Automatic Bilge Pump 650 US GPH,12V Bulk Packaged
SS5412B	Supersub Smart - Low Profile Automatic Bilge Pump 650 US GPH, 12V , 4 way Deutsch connector, Bulk Packaged
SS5512B	Supersub Smart - Low Profile Automatic Bilge Pump 650 US GPH, 12V Bulk Packaged WEATHER BO

\* Please note: 3 year warranty also applies to Whale’s manual versions of the Supersub.

For further information, please contact your Whale Account Manager.

Yours sincerely,

Rodney Sanderson

Commercial Director

